

# JOHNSON<sup>®</sup> INDUSTRIAL SCREENS

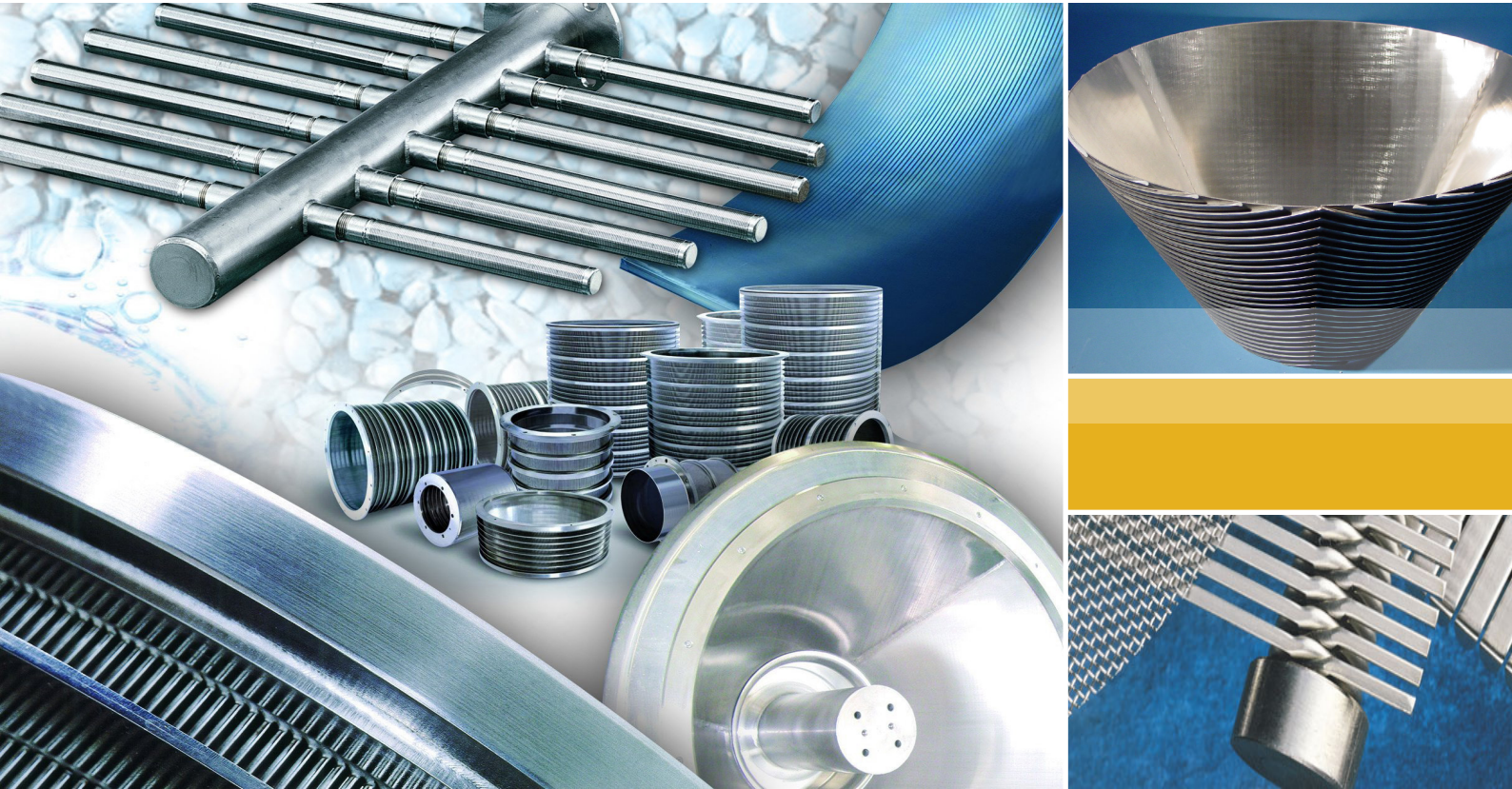

**Johnson** screens<sup>®</sup>

# JOHNSON SCREENS®: AN OVERVIEW

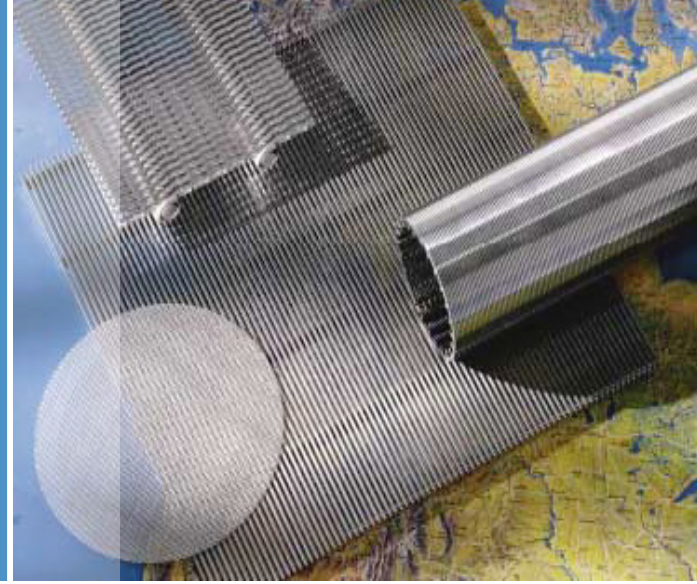

## INNOVATIVE DESIGN

Johnson Screens is an international company specialising in the design and manufacture of stainless steel filter elements for liquid/solid and gas/solid separation.

Our screens are known for great strength, long service life and a very high level of adaptability for high-efficiency liquid/solid separation.

Johnson's screens are made by welding vee-shaped Vee-Wire® on support rods, creating slots which enlarge inwardly, meeting the most demanding standards for ruggedness, durability, consistency and slot openings. The vee-shaped opening allows only two contact points with the particles, thus preventing any risk of clogging.

### CUSTOM DESIGNED AND ENGINEERED

Each project is designed to ensure complete satisfaction. We provide guidance and support from project conception to completion.

### LONGER LASTING

Johnson's manufacturing standards are the most stringent in the industry. Featuring the patented Vee-Wire technology, the screens are extremely durable and have high resistance to abrasion, corrosion and impact damage.

### LOWER MAINTENANCE

The rugged construction and high quality of the materials produce a product that lasts longer and requires less maintenance.

### LESS COSTLY

Superior operating efficiency, reduced maintenance needs, and extended service life combine to decrease the cost of Johnson's screens to plant operators.

### MANY CONSTRUCTION OPTIONS

Johnson's screen surfaces can be used:

- For direct screening
- As filter media support (sand bed, activated carbon, resins, catalysts)

Screens are available in slot opening from 25 micron up to 25 mm. Most common materials used are 300 series stainless steel, but many exotic alloys are available to suit specific applications.

Screens are available in a variety of shapes to suit customer needs:

- Cylinders
- Flat or curved panels
- Cones
- Any form specific to a given application

The flexibility of the process allows the manufacture of custom made screens for all types of applications: new plant, expansions or upgrades.

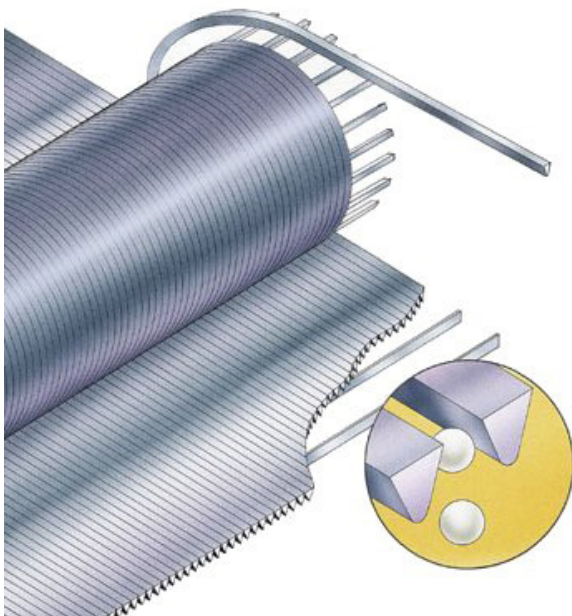





## A HIGH TECHNOLOGY PRODUCT

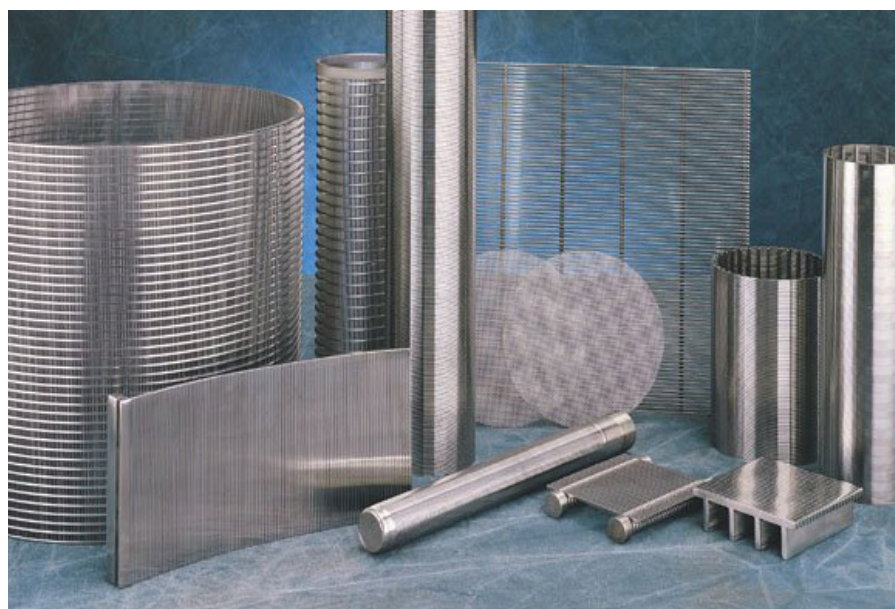

The design and manufacturing characteristics of Johnson's screen surfaces provide the following advantages:

- Non-clogging surface
- Large open area
- Low pressure drop
- Hydraulic efficiency
- High flow rates
- Mechanical strength
- Abrasion-resistant
- Easy cleaning

## MANY AREAS OF SCREEN APPLICATION

The strength, precision and design flexibility that characterise our screens makes them the choice in a broad range of industries and applications.

### Market/Industry

- Water and waste water
- Pulp and paper
- Chemical
- Petrochemical
- Water supply
- Mineral and aggregate processing
- Plastics extrusion
- Machine coolant filtration
- Architectural applications

If your process involves any aspect of fluid/solid separation, we have the products and experience to help you achieve maximum efficiency and effectiveness.

### Applications

- Separating
- Filtering
- Media retention
- Sizing
- Dewatering
- Classifying
- Straining
- Drying
- Water intake
- Fish diversions

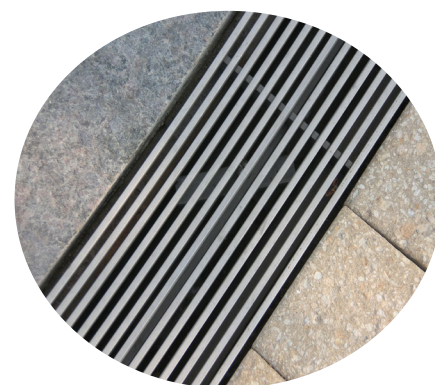

# THE DESIGN

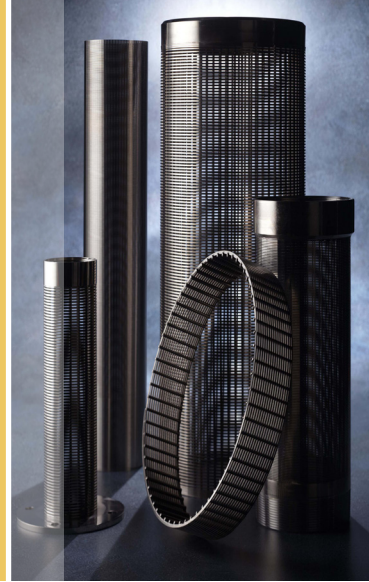

## CYLINDRICAL SCREEN FOR OUTSIDE → INSIDE FILTRATION

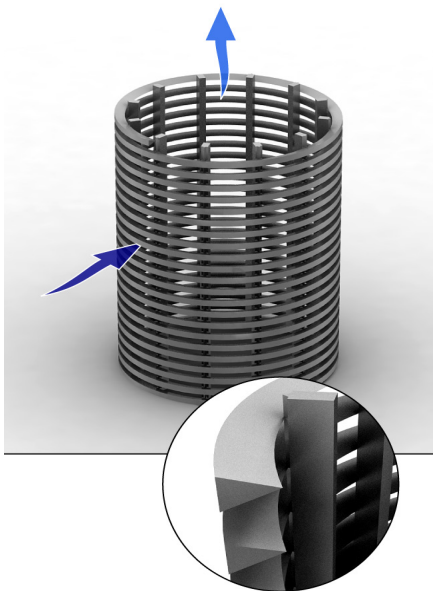

### STANDARD

External circumferential wire and axial internal support rods.

#### Benefits:

- Economical
- Suitable for most applications
- Precision openings

#### Products:

- Filter cartridges
- Diatom candle filters
- Header laterals
- Rotating drum screens
- Nozzles
- Resin traps

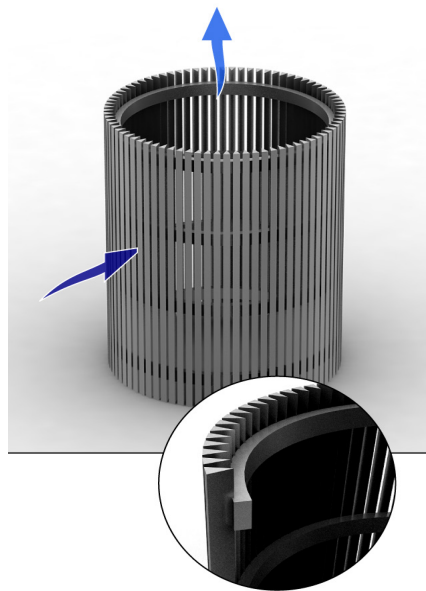

### EXTERNAL AXIAL WIRE (re-rolled)

External axial wire with internal circumferential support rods.

#### Benefits:

- Facilitates cleaning with an external axial-movement scraper

#### Products:

- Automatic filters

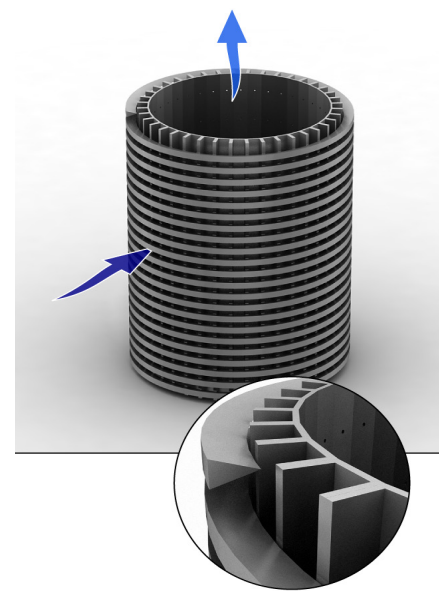

### CHANNEL ROD CONSTRUCTION

Perforated U-section channels replace the internal support rods. When the filter is used as a collector, flow is outside-in. When it is used as a distributor, flow is inside-out.

#### Benefits:

- Optimised collection and distribution
- Replaces perforated inner tube

#### Applications:

- Potable water treatment
- Ion exchange
- Oil refining processes





## CYLINDRICAL SCREEN FOR INSIDE → OUTSIDE FILTRATION

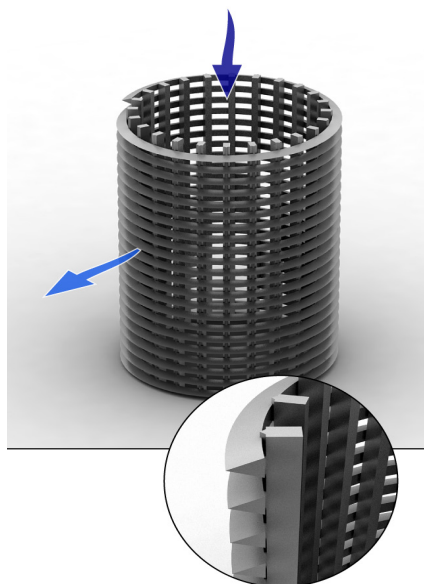

### INVERTED

External circumferential inverted wire and axial internal support rods.

#### Benefits:

- Economical

#### Applications:

- Inside-out flow

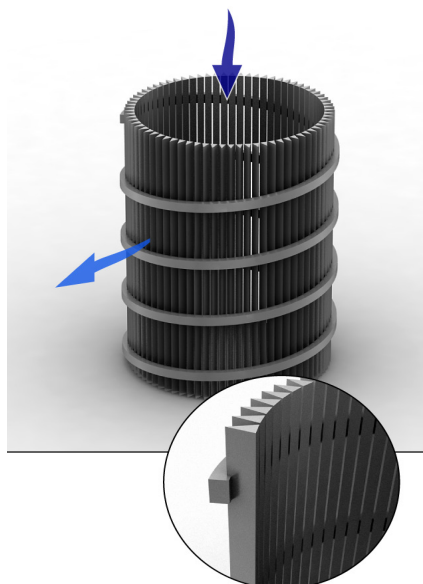

### INTERNAL AXIAL WIRE

(wire-base)

Internal axial wire with external circumferential support rods.

#### Benefits:

- Smooth internal screen surface
- Facilitates cleaning with an internal axial-movement scraper
- The flow moves across the wire edges for effective dewatering

#### Products:

- Trommel screens with internal feed
- Systems with an internal rotor or screw
- Dewatering systems
- Baskets
- Automatic filters

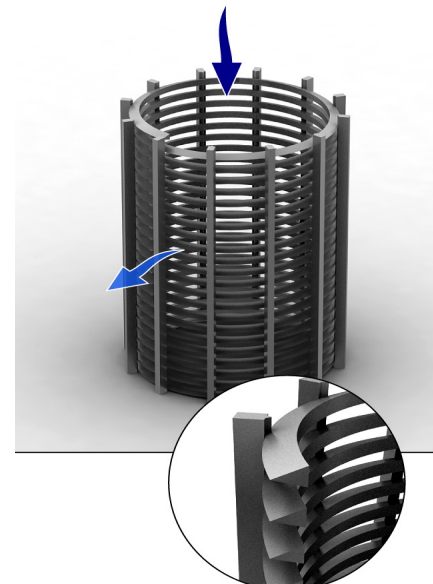

### INTERNAL CIRCUMFERENTIAL

WIRE (re-rolled)

Internal circumferential wire with external axial support rods.

#### Benefits:

- Smooth internal filter surface
- Custom inner diameter

#### Products:

- Screw press

# PRODUCTS

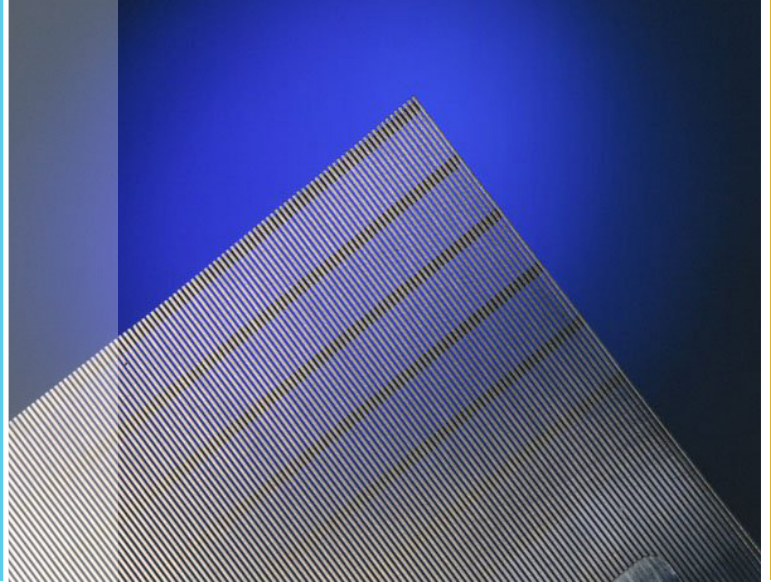

## FLAT SCREENS

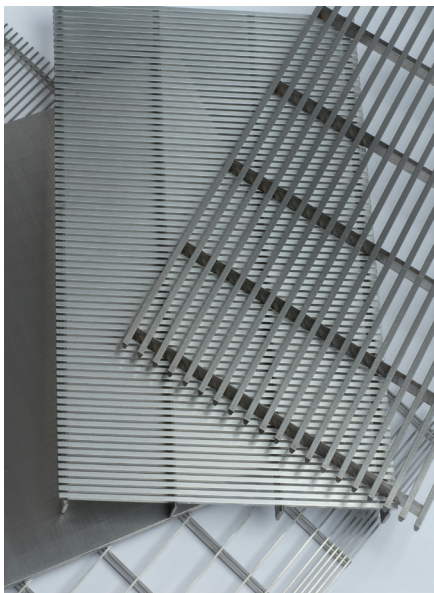

Johnson's flat screens can be fabricated with very small wires and rods for critical fine-screening operations, or with much larger wires and rods for heavy-duty operations.

The slot size is determined according to the customer's needs and application.

Currently used as:

- Filter floors
- Support grids
- Static grids
- Vibrating screens
- Floor grates



Johnson's screens can be used in numerous applications, such as this lauder tub, used to separate grains from the wort in the brewing process.

## SUPPORT GRIDS

The support grid system is available in an assortment of framing options and designs - as a one-piece construction or in multiple sections for on-site assembly and ease of retrofitting through existing manways.

Because of their strength, durability and flow characteristics, our support grids are widely used in hydrotreaters, desulfurisers, molecular sieves, gas sweeteners, ion exchangers and other absorption systems.



### BENEFITS

- Self-supporting structure
- Exceptional resistance to collapsing or buckling, even in operations where screens must withstand extremely high loads
- More effective open area than grids using wire mesh on grating
- Smooth surface of the screens reduces abrasion of media

### FEATURES

- Slot size can be designed for direct media retention
- Grids can be supplied with support beams, rope packing, bolting and all necessary accessories

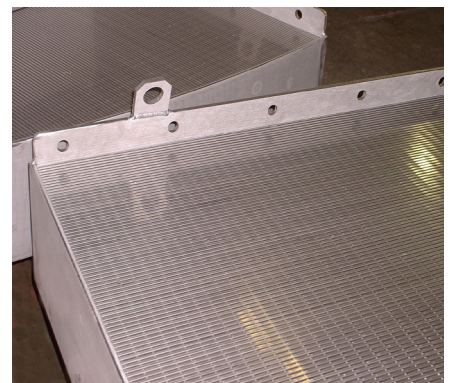

This self-supporting filtration structure is used in down- or up-flow systems to retain the reactive media while allowing the liquid to pass through.





## CANDLE FILTERS



Candle filters are filter elements with the following qualities:

- Small diameter usually less than 50mm
- Substantial length usually greater than 1,000 mm
- Very fine openings: 25 to 150 microns, according to the application

Candle filters can be used:

- For direct filtration
- As medium support (for example diatoms in precoat filters)

The filtration capacity can be modified easily by varying the number of candle filters to obtain the required filter area.

### CLEANING

A stronger flow in the backward direction, known as backwash, cleans the candle filters effectively.

### MAINTENANCE

Because the filter elements are particularly rigid and rugged, they can be disassembled without risk of damage to the filter surface.

## CARTRIDGES

A large range of industries use cartridges. Rugged, precise and easy to clean, these filter elements are suitable for all industrial processes.

They can be used for:

- Conventional filtration, outside-in
- Reverse filtration, inside-out

The use of extremely fine wire maximises the open area. This process is all the more true for slots smaller than 100 microns.

The following types of fittings can be welded to allow incorporation of cartridges into any process:

- Collars
- Flanges
- BSP or NPT threaded end fittings
- Machined rings for fittings with O-rings or flat baskets
- Other fittings



# PRODUCTS



## NOZZLES



Nozzles are used in liquid/solid or gas/solid separation. Their design and quantity will vary depending on application and customer-flow requirements. Nozzles allow a more effective use of the treatment media.

Common applications include:

- Collectors and distributors installed uniformly across a plate or a header lateral arrangement
- Demineralisers, water softeners and in pressure and gravity sand filters

### BENEFITS

- Economical design
- Non-plugging design
- High open area
- Increased strength and corrosion resistance

### FEATURES

- Standard diameter: 50 mm
- Typical slot opening ranging from 0.2 mm to 0.5 mm
- Threaded end fittings or "L" bolts
- Primarily made of stainless steel; however, special spherical nozzles made from ABS or Kynar® are also available.

## RESIN TRAPS

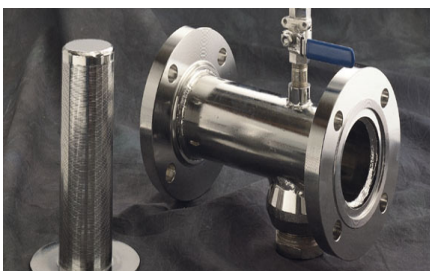

A resin trap is a safety device used on the overflow lines of ion exchange units, high-purity water systems and activated carbon and media filters.

In many systems, a valve failure can allow media to escape from the treatment vessel. Not only is the loss of expensive media significant, but damage can easily occur to downstream pumping equipment.

Johnson's resin traps, placed inline, provide positive protection. The traps can be designed to capture media particles of any size.

### BENEFITS

- Prevents expensive resin/media loss into piping distribution system
- Protects downstream pumping equipment
- Visibility of minor resin/media losses in prevention of major equipment failure

### FEATURES

Continuous slot design, allowing traps to capture media particles of any size, providing sufficient open area to let process flow move smoothly

- Stainless steel construction (other alloys can be used depending on pressure and temperature)
- Various options for sizes, shapes and connections, depending on process flow characteristics
- Designed for full system pressure







## SCREEN LATERAL SYSTEMS



Header lateral design can be either side-mounted or have a center outlet.



These assemblies consist of a series of screen laterals connected to either a central header pipe or a hub. They are designed for effective media retention in a wide range of applications, including ion exchangers, clay and sand filtration applications, and carbon towers.

### BENEFITS

- The design allows a uniform collection or distribution flow of a gas or liquid through treatment media without dead zones
- The system can accommodate a wide variety of vessel sizes and shapes with side, center, top, or bottom inlet piping
- The assemblies can be designed to accommodate flow in any direction.

### FEATURES

- Lateral spacing, length, diameter and slot opening sizes are based on individual system needs: slot size 0.05 mm and up in increments of 0.01mm and diameter from 20mm up
- Assemblies are typically made with type 304SS, 316LSS, or other exotic alloys
- Connections of the laterals can be threaded fittings, couplings or flanges

## FRACTAL COLLECTORS & DISTRIBUTORS



Johnson Screens has patented an advanced collector distributor system design that allows for fractal control of fluid flow in a media. This flow is demonstrated by the even distribution of the dye through the water.

This system is fractal, in that the residence time for a path through the upper header/lateral, media, and collector header/lateral is the same for each exit/entrance pair in the system.

This system can be used in applications such as ion exchanges, resin beds and any chromatic process.

These advanced screen assemblies allow better use of the media and an increase in overall process efficiency. These types of specialised designs come from the advanced engineering methods and tools Johnson Screens maintains to serve the needs of its customers.

### BENEFITS

- Equal contact time with media
- Equal resonance time in the system
- Effective plug flow
- High distribution efficiency

### FEATURES

- Lateral exit flow variation, as little as 3 percent, for the entire assembly
- Various options for sizes, shapes and flow capacities available
- Distributors are typically made with type 304SS or 316LSS. Other alloys are also available

# PRODUCTS



## SIEVE BENDS AND BOXES



A sieve bend has a greater screening capacity than a flat screen due to forces exerted as material flows against the curved surface. This curved profile wire screen is mounted in a frame with the screen openings perpendicular to the flow.

In a typical feed situation, the leading edge of the wedge wire removes the water and fine particles through the screen up to the cut point size, as the oversized particles move across the top of the screen.

Separation size is considerably smaller than screen openings, usually about one-half the opening size.

Sieve bend screens are ideal for sizing and dewatering applications in liquid/solid separation situations. It is extensively used for fine fiber removal in the starch industry. It is also used in other industries such as food processing, waste water cleanup and corn wet milling.

### BENEFITS

- Reduced equipment and installation costs
- Low maintenance costs (no moving parts)
- Better flow rate and finer fiber removal
- Little space needed
- Wide range of applications
- Longer lifetime

### FEATURES

- Width, length, aperture and wire depend on flow rate and size of particles to be separated
- Slot sizes range from 25 micron to 10mm
- Screen material is typically 304 or 316 SS with end bars. Other materials are available upon request

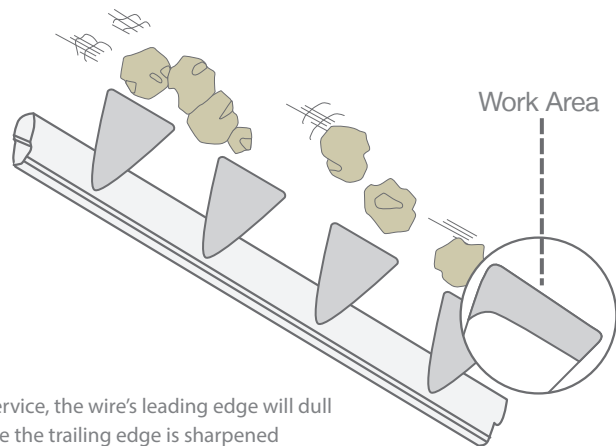
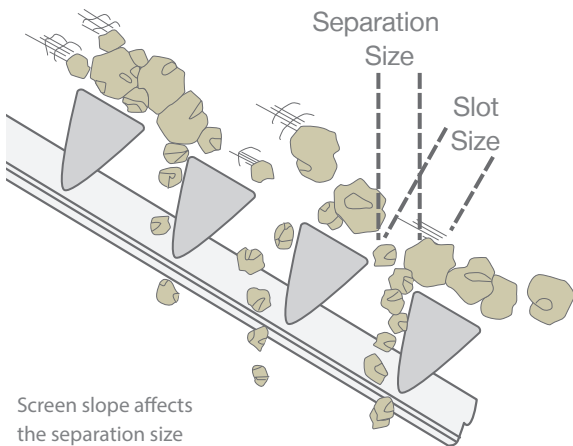



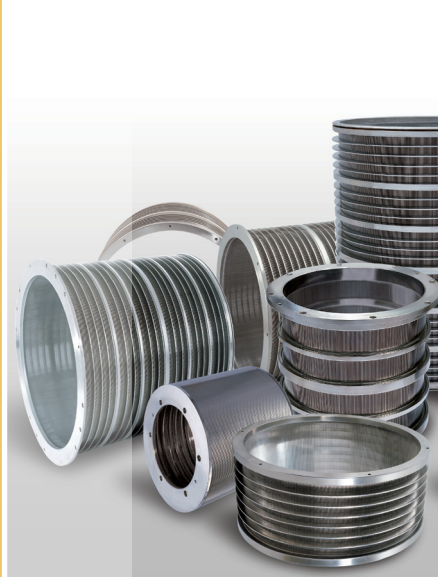

## CYLINDRICAL BASKETS



Cylindrical baskets can be designed for a flow from out to in (standard construction) or from in to out (re-rolled construction). They are perfectly round and are adapted for self-cleaning filters or screw press filters. They can be cleaned with static scrapers.

### BENEFITS

- Self cleaning surface
- High open area
- Strong construction

### FEATURES

- Dimensions adaptable to any specific needs
- Large range of constructions (wires, rods)
- All slot sizes from 25 micron
- Flanges and reinforcement rings available depending on the application

## CONICAL BASKETS

These conical baskets for centrifuges are widely used in the sugar and starch industries for dewatering processes (high-speed machinery).

This self-supporting structure is especially designed and engineered to withstand the high stresses and load conditions of these processes.

Their unique design ensures:

- A high mechanical strength, thus extending wear life
- A precise slot opening and larger percentage of open area, thus increasing capacity

### BENEFITS

- Fast and easy installation
- Long life
- High resistance to abrasion, corrosion and damage by foreign objects, leading to lower maintenance
- High dewatering efficiency

### FEATURES

- In particularly severe conditions, different reinforcements can be added
- Special alloys and anti-abrasion coatings are also available upon request

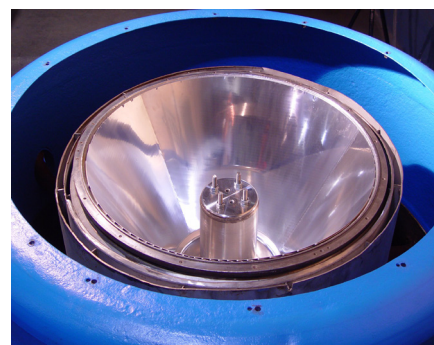

# PRODUCTS

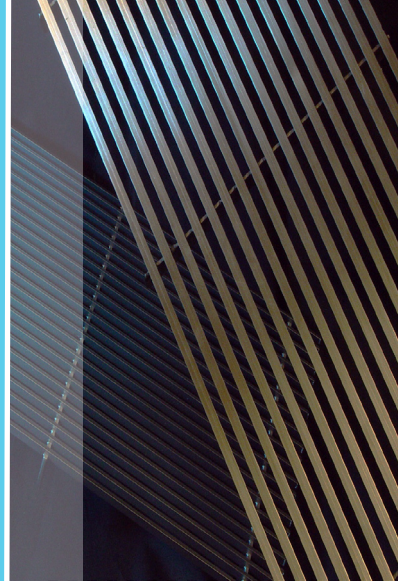

## PRESSURE SCREENS

Pressure screens are mainly used for the stock preparation in the pulp and paper industry. They can be used for any application regarding fiber or fine grain filtration.

### BENEFITS

- The continuous slot gives a greater performance thanks to a higher open area

### FEATURES

- Specific wire shape
- Diameters from 200 to 500 mm
- Reinforcement of the process
- Balanced

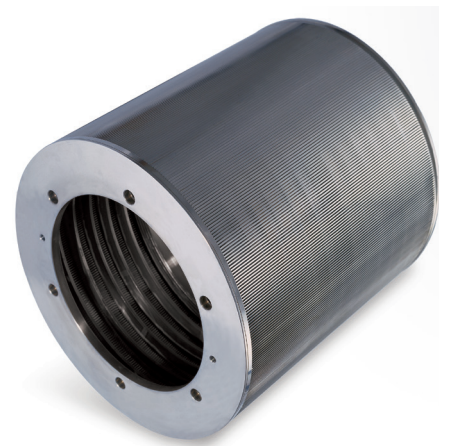

## SCREW PRESS

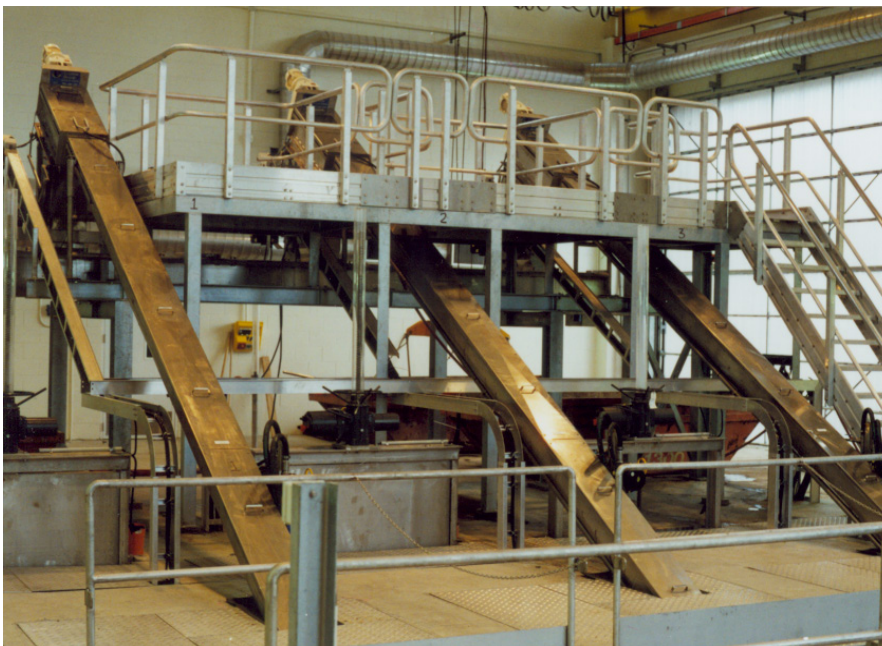

For dewatering using a screw press, Johnson Screens can provide a screen designed to meet your exact specifications. Our high-strength design can withstand the rugged operation while providing an accurate slot width and maximising open area to maximize dewatering.

For use in numerous industrial designs. Abrasion resistant options available.

### BENEFITS

- High-strength design
- High open area

### FEATURES

- Accurate slot width
- Custom designed to fit any application



# SUPPORT



## FIELD SERVICE

Johnson Screens offers a complete field service activity with a team of specialised and experienced supervisors available for various interventions like:

- Full installation
- On-site repairs
- Technical assistance or expertise
- Work supervision
- Inspection



Our flexibility and expertise allow us to propose this extended scope of services under tailor-made contract conditions in order to better serve our clients' requirements.

## QUALITY

Johnson Screens management is convinced that a successful approach to health, safety and the working environment is an integral part of effective and forward-looking company management.

Johnson Screens has been ISO-certified ; each product is subject to a procedure of self-inspection by each operator throughout the manufacturing process.

A final inspection guarantees delivery of a product which fully meets the user's technical specification.

Johnson Screens can provide the following documents upon request:

- Quality plan
- Manufacturing plan
- Production schedule
- Welding procedure (WPS)
- Process qualification (PQR)
- Welder qualification (WQR)
- In-house inspection reports
- Chemical and/or mechanical analysis certificates

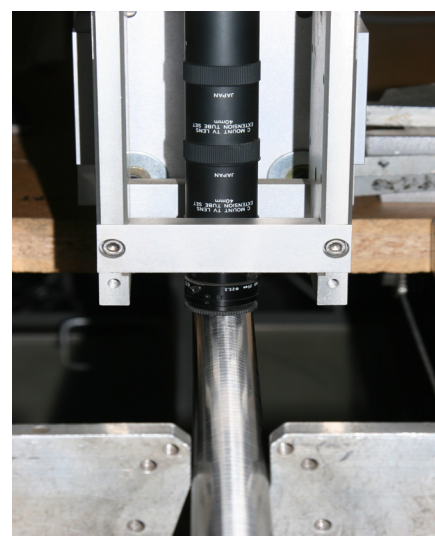

One of our quality inspection techniques includes this unique laser technology, allowing us to check the wire spacing of fine-wire screens.



# TECHNICAL DATA

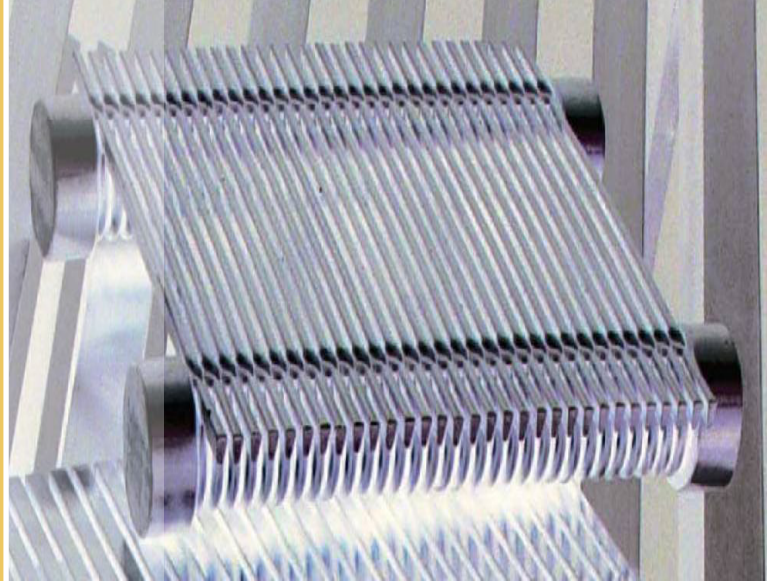

## STANDARD WELDED CONSTRUCTION



Johnson Screens standard welded construction uses resistance-welding in a continuous rolled motion to join the wire and rods. The resistance welds the continuous length of wire to the rods as it circulates.

Screens can be made in various different formations, including cylindrical, flat, or curved.

Any variation of wire and rod sizes as well as slot opening can be chosen to develop the exact screen of your choice. Screens are available in slot opening from 25  $\mu\text{m}$  up to 25 mm. Most common materials used are 300 series stainless steel, but many exotic alloys are available to suit specific applications.

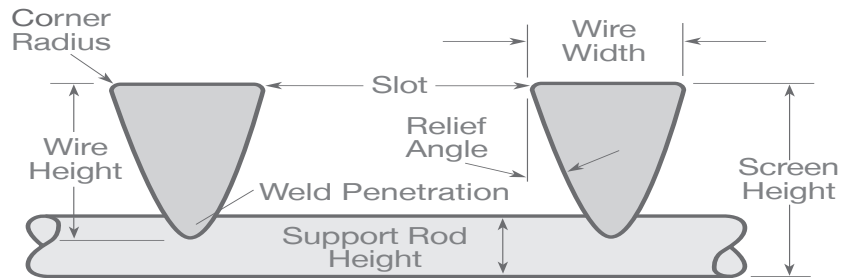

## LOOPED WIRE CONSTRUCTION

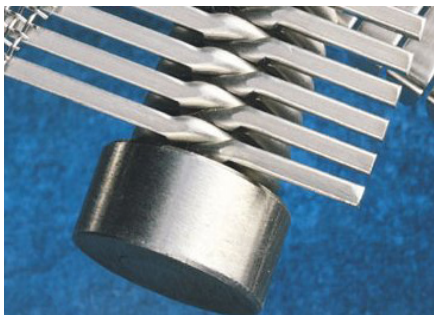

Looped wire profile screens are used in a variety of applications.

Loop construction eliminates a welding requirement to join the rod and wire, as well as greatly increasing the durability of the screen in many applications.

Our loop wire manufacturing process allows for a great degree of flexibility in producing various profile shapes, openings and support-member configurations.

Flexible manufacturing gives us the capability to manufacture screens using 304SS and 316LSS, as well as other alloys.

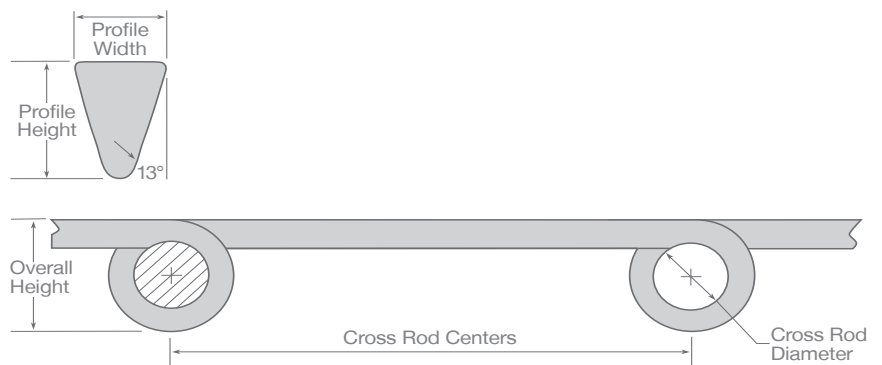





## WIRES AND RODS INFORMATION

A wide range of wire and rod shapes make it possible to achieve the optimum balance of strength, open area, abrasion resistance and dewatering/separation efficiency.

### JOHNSON SCREENS® ROUND AND STRIP SUPPORT RODS

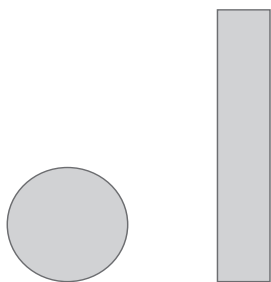

Johnson Screens round rods are available in diameters ranging from 3.175 mm to 12.7 mm.

Strip rods are available in widths from 1.778 mm to 4.775 mm and heights ranging from 9.525 mm to 50.8 mm.

### OPEN AREA CALCULATIONS

To calculate the open area of a certain screen, use the simple formula provided:

$$\text{Open Area (\%)} = \frac{\text{Slot size} \times 100}{\text{Slot size} + \text{Wire width}}$$

### JOHNSON SCREENS VEE-WIRE® PROFILES

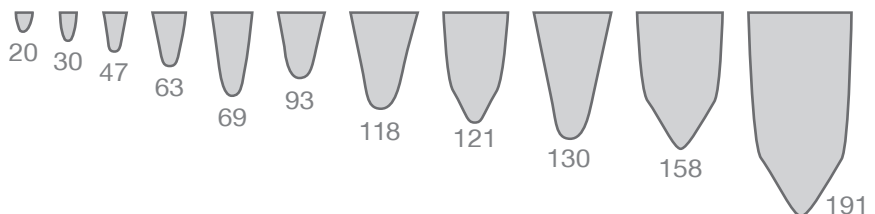

Johnson Screens Vee-Wire Profile wires range in widths from 0.508 mm to 4.953mm and heights ranging from 1.016 mm to 9.220 mm.

Other wire shapes (Tri-Wire, Iso-Wire, Iso-Grizzly Wire, Grizzly-Wire, etc.) are also available.

### COMMON JOHNSON SCREENS SHAPED SUPPORT RODS

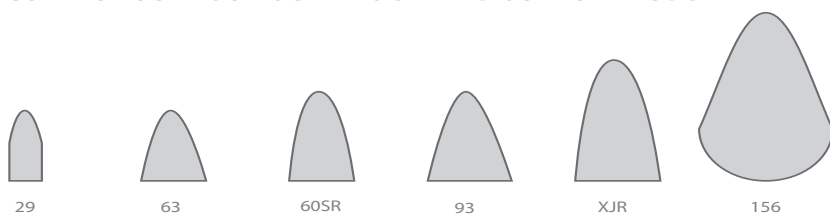

Johnson Screens shaped support rods range in widths from 0.737 mm to 3.835mm and heights ranging from 2.591 mm to 3.048 mm.

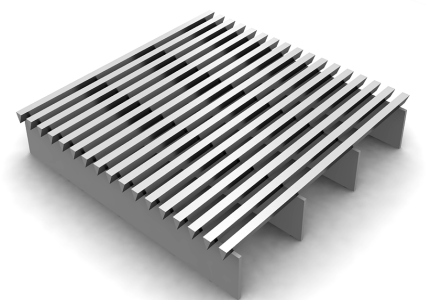

Providing over 100 years of experience,  
innovation and customer satisfaction.  
Contact us today.



## OUR WIDE RANGE OF PRECISION ENGINEERED EQUIPMENT IS SUITABLE FOR MORE APPLICATIONS THAN EVER.

Turn to Johnson Screens® to help maximise your operational efficiency and find long-term, trouble-free solutions. Discover our ever-expanding range of products, designed with your needs in mind:

### GENERAL INDUSTRIAL

- Flat panels
- Sieve bends
- Cylindrical screens
- Centrifugal baskets
- DSM screens
- Trommels
- Vibrator screens
- Diffuser screens
- Pressure screens

### ARCHITECTURE & CONSTRUCTION

- Column covers
- Urban furniture
- Frontages
- Floor grating
- Furniture
- Ventilation grids
- Sun-control screens
- Custom lighting
- Wall partitions

### WATER PROCESS

- Passive Intake screens
- In-line self-cleaning filters
- Nozzles
- Triton® underdrain systems
- Fish diversion screens
- Collectors/distributors
- Resin traps
- Precoat filters
- Milliscreen®
- Suboscreen®
- Stepscreen
- Centre-Flo Screen

### WATER WELL

- Well screens (stainless steel and PVC)
- Riser pipes
- Sand spears
- Environmental monitoring screens
- Drilling fluid
- Nu-Well® rehabilitation chemicals

### MINERAL & AGGREGATE PROCESSING

- Centrifuge baskets
- Pipo® modular screening systems
- Koko® screening systems
- Specialty wire & polyurethane combination screens
- Sieve bends
- Trommel mats
- Spray Nozzles
- HDPE Pipes
- Ceramics
- Rubber screening systems
- Mill liners & Rubber ceramic wear liners
- Urethane lined pipe

### PETROCHEMICAL AND REFINING

- Centerpipes
- Outer baskets
- Scallops
- Support grids and beams
- Outlet collectors
- Laterals
- Distributor trays
- Nozzle systems
- Scale traps

### ON-SITE SERVICES

- Installation
- Inspection
- Repair
- Assistance
- Supervisor

Aqseptence Group  
Zone Industrielle  
86530 Availles-en-Châtellerault  
FRANCE

Phone + 33 5 4902 1600  
Fax + 33 5 4902 1616  
france.water@aqseptence.com  
www.aqseptence.com

Bilfinger Water Technologies has  
become Aqseptence Group.



**Johnson  
Screens**

A brand of  
Aqseptence Group